

NASH Vacuum Pumps & Compressors for Belt Filter Applications



Horizontal Belt Filters

These are the most common vacuum filters in industry, due to flexibility of operation, adaptation to corrosive slurries and the ability to handle large throughputs. They operate at high rates and can reach operation speeds in excess of 50 m/min., and can yield very short cycle times.

The belt filter is comprised of:

- Belt - this endless rubber belt drains the filtrate toward holes positioned along the belt. The sides of the belt have shrouds to contain the slurry and the cake.
- Filter Cloth - this retains the cake and moves with the belt.
- Vacuum Boxes - the vacuum boxes are below the belt. They collect the filtrate through a manifold.
- Feed and Wash Boxes - mounted over the filter and designed to evenly distribute the slurry and wash water across the belt.
- Cake Discharge - At the end of the filter, the cycle terminates and the cloth separates from the belt. The cloth continues moving over a discharge roll and discharges the cake into a chute.
- Belt Supporting Deck - attached to the frame and mounted underneath the belt, it is designed to support the heavy rubber belt and the cake load.
- Filtrate Manifold - collects the liquids to one of the vacuum receivers.

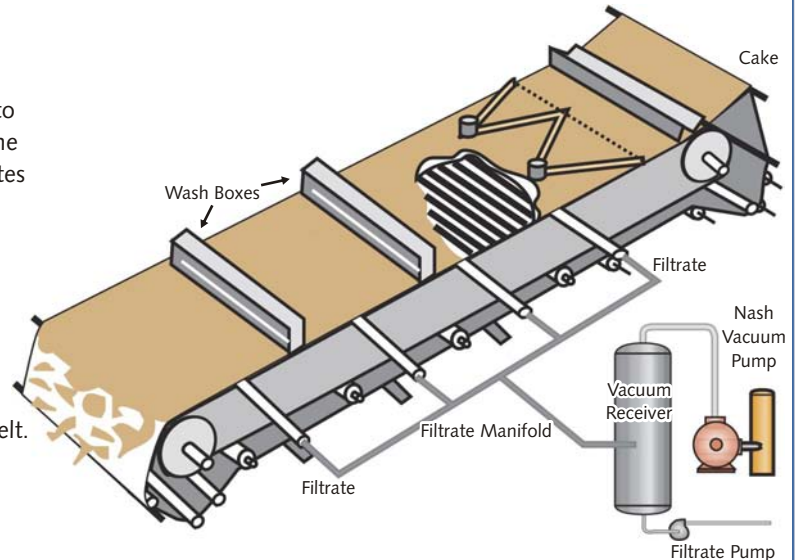

Belt Filter Vacuum System
Photo courtesy of Larox



Belt Filter Vacuum System
Photo courtesy of WesTech

Selection Criteria

- For solids that are fast settling and cannot be kept as a homogenous slurry
- When long drying time is required
- When short cycle times are required for fast dewatering of cakes, such as phosphate slurry
- When intensive cake washing is required
- If a clear filtrate is required
- When cakes tend to crack under vacuum
- When scale formation due to flash evaporation is a problem
- When filtrate temperature must be maintained
- When the cake tends to clog the cloth

Typical Applications

- | | |
|----------------------------|-------------------------------|
| Catalysts | Phosphoric acid |
| Potash | Chemical processing |
| Agricultural products | Corn |
| Industrial water treatment | Mining and mineral processing |

**Gardner Denver
Engineered Products Division**
9 Trefoil Drive, Trumbull, CT 06611
phone: +1 800 553 NASH
fax: +1 203 459 3988
nash@gardnerdenver.com
GDNash.com